



# LABS

Life And Building Safety

## LABS Design Requirement

---



**Please register yourself**

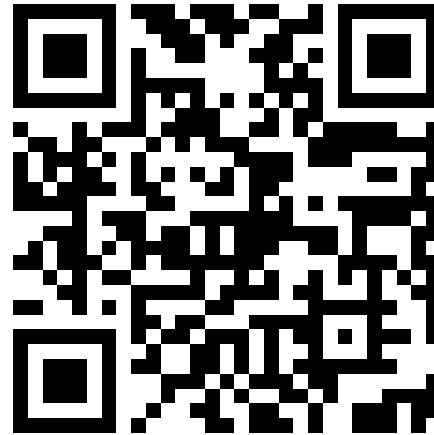

*<https://forms.gle/n96P9ZuepHn3MAxR6>*



# ☰ INDEX

1. Why is Design Required?
2. Flow of Design Approval
3. Design Timeline
4. Design – Electrical Safety
5. Design – Fire Safety
6. Design – Structural Safety

# Why is Design Approval Required?

Remediation being done align and within the framework of LABS Standards per signed off CAP and approved by IF.

## What is Design Approval?

Post CAP Sign-off process, the Factory and RF prepares and uploads the design on the LABS FFC platform for due evaluation and subsequent signing-off by the Inspection firm prior to initiation of remedial actions.

Design Approval will be required in cases such as:

1. Product details, manufacturer certifications, design review and specifications for Fire rated doors, fire-fighting systems such as smoke detectors, sprinklers, hydrants etc.
2. As built drawings are not updated as per the actual installations.
3. Drawings/ Plans/ Layouts are missing approval and stamp from local authority or are not signed and approved by the Government Engineer
4. Single line diagrams, As-Built drawings and plans for new/old electrical systems and installations, HV & LV Distribution systems, power supply, Lifts, Earthing layouts, Lighting protection systems etc.

# Flow of Design Approval

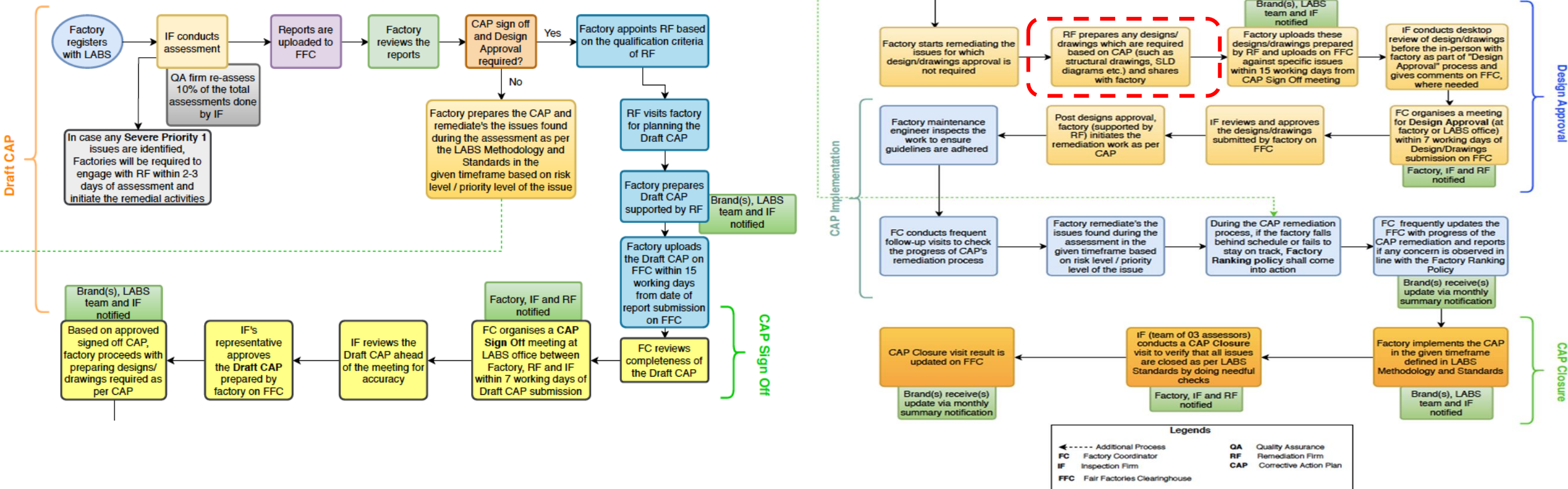

# Design Timeline Based on the LABS Standard

Discipline	Document	Preparation/Sub mission Timeline for RF*
Fire Safety	Product details, manufacturer certifications, design review, specifications along with detailed floor plan for fire-fighting systems such as smoke detectors, sprinklers, hydrants etc.	60 Days
	Product details, manufacturer certifications, design review and specifications for Fire rated doors	45 Days
	Certified as built drawings to reflect actual installations of firefighting systems	60 Days
	Approval and stamp of Government Engineer from local authority on Drawings/ Plans/ Layouts	90 Days
	Fire rated separation/compartimentation drawings/designs (Between hazardous and non-hazardous areas, lift lobby, exit staircase, exit pathways, etc.)	60 Days
	Increasing capacity of water tank – Design/Layout of the tank	60 Days
	Floor wise emergency escape plan/layout	45 Days
	Design/drawings for additional staircase (external)	90 Days
	Design/drawings for replacement of rolling shutters with Fire rated doors	60 Days
	Firefighting system designs – addition of pumps (diesel, jockey pump)	60 Days
Electrical Safety	Power supply schematics (Load plan) highlighting the Information related to electrical load distribution	30 days
	Single line diagrams/ As-Built drawings and plans for new/old electrical systems and installations	45 days
	HV & LV Distribution board schematics	45 days
	Earthing layouts	30 days
	Lightning protection systems – risk assessment report, radius of protection drawings	90 days
	Approval and stamp of Government Engineer from local authority on Drawings/ Plans/ Layouts	45 days
	Product details, manufacturer certifications, design review and specifications of new electrical components to be installed such as Boilers, Transformers, Emergency lights, Generators, Electrical Panels, Wires and Cables etc.	90 days
Structural Safety	Structural drawings for foundations, columns, beams, etc.	60 days
	Building plans	30 days
	Site layouts	15 days
	As-built drawings	30 days
	Load plans for suspended floors highlighting the actual loads vs. maximum loads	60 days
	Geotechnical/Soil test report	30 days
	Designs for any additions/ alterations in the structural and non-structural components	60 days
	Design/drawings for non-engineered structures	60 days
	Seismic analysis, along with certified report	30 days

(A timeline of 03 working days has already been considered in the above table for the site visit to be carried out by a Remediation Firm to initiate work on designs/drawings)

**Design – Electrical Safety**



# Single Line Diagram – Finding & LABS Requirement

Issue: No SLD in the electric panel for review, the SLD is outdated, and No diagram/lay out for fire detection and alarm system for review.

## LABS Standard

### 10.12.2 Wiring of Distribution Boards

- (1) In wiring, a distribution board, total load of the consuming devices shall be distributed as far as possible evenly between the phases.
- (2) Outgoing cables shall be connected to terminals only by soldered or welded lugs, unless the terminal is of such form that it is possible to securely clamp them without cutting away the cable strands. Terminals shall be wired to the correct circuit protective device.

**10.22.3** For new and existing buildings, a Single Line Diagram (SLD) shall be maintained and continuously updated to reflect as built conditions. The SLD shall show a correct power distribution path from the incoming power source to switchgear, switchboards, panelboards, MCCs, fuses, circuit breakers, automatic transfer switches and continuous current ratings.

During the review of the single line diagram (SLD), a sample check of conductor sizes against protective devices shall be carried out to give an indication if there are unprotected cables. Functional testing of conductors shall not form part of the assessment.

Why SLD Design is required? To avoid any safety related electrical system such as the fire detection and alarm system not being installed properly.

# Single Line Diagram – Master Plan

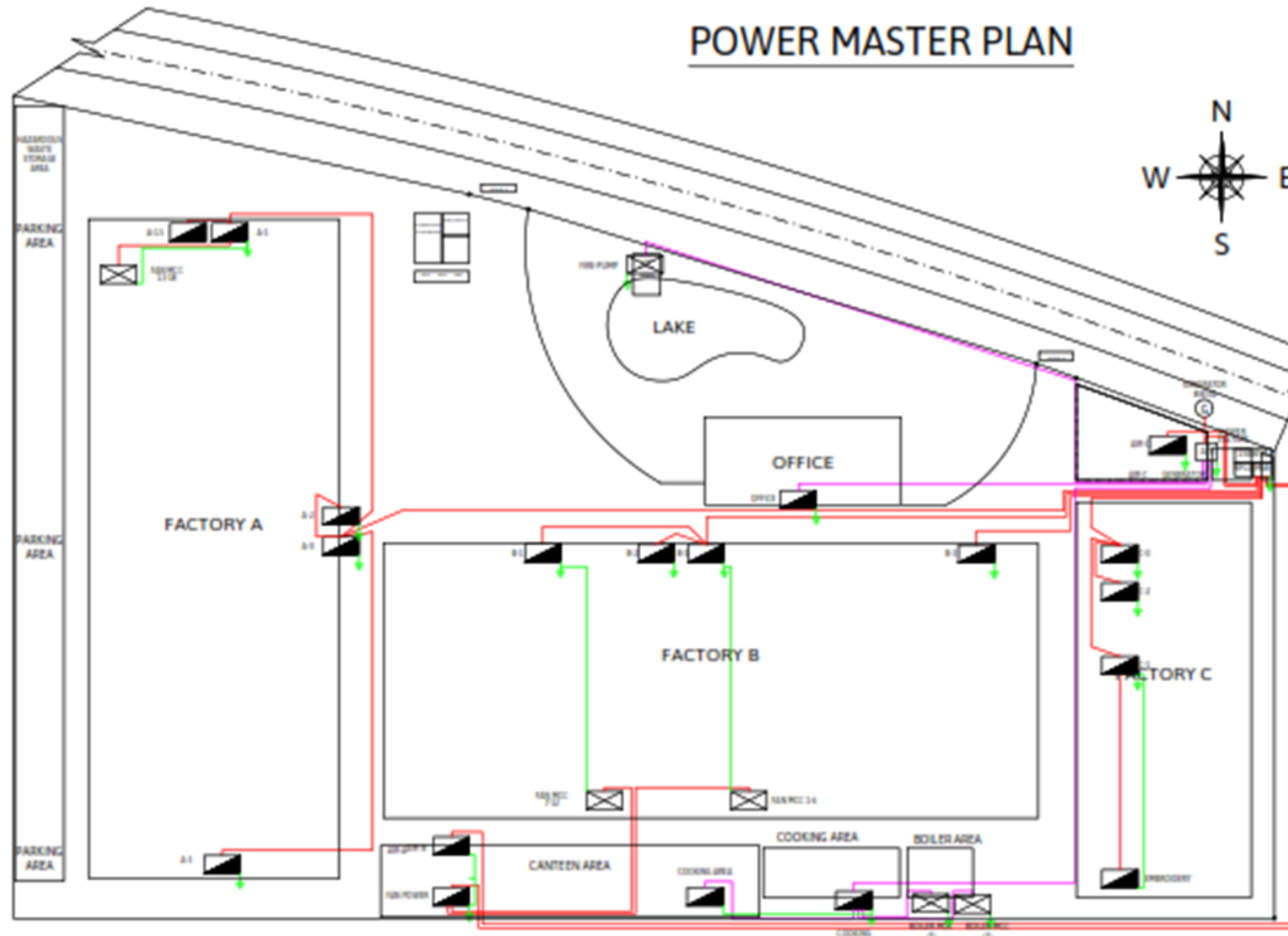

## Basic Requirement for SLD:

1. Location of all importance equipment (transformers, Generators, Main distribution boards/panels, air compressor, boiler, fire pumps, etc.) and the identification names of equipment and electrical boards/ panels.
2. Wiring general layout and information which included: cable size, cable type, length with Panel/ Equipment rated current (Equipment detail information - Load type, capacity).
3. Incoming service voltage (PLN).
4. Bus voltage, frequency, phases, and short circuit current withstand ratings.
5. Transformer connection type, kVA, voltages, and impedance, alongside with Generator voltage and kW.
6. PE layout included: Cable sizes (refer to table 10.35.2), #of cables.
7. Protection equipment specification: Type (MCCB, CB, MCB, ACB ...), protection range.
8. Alignment calculation between incoming voltage, wiring, PE, protection equipment and load.

# Single Line Diagram – Master Plan

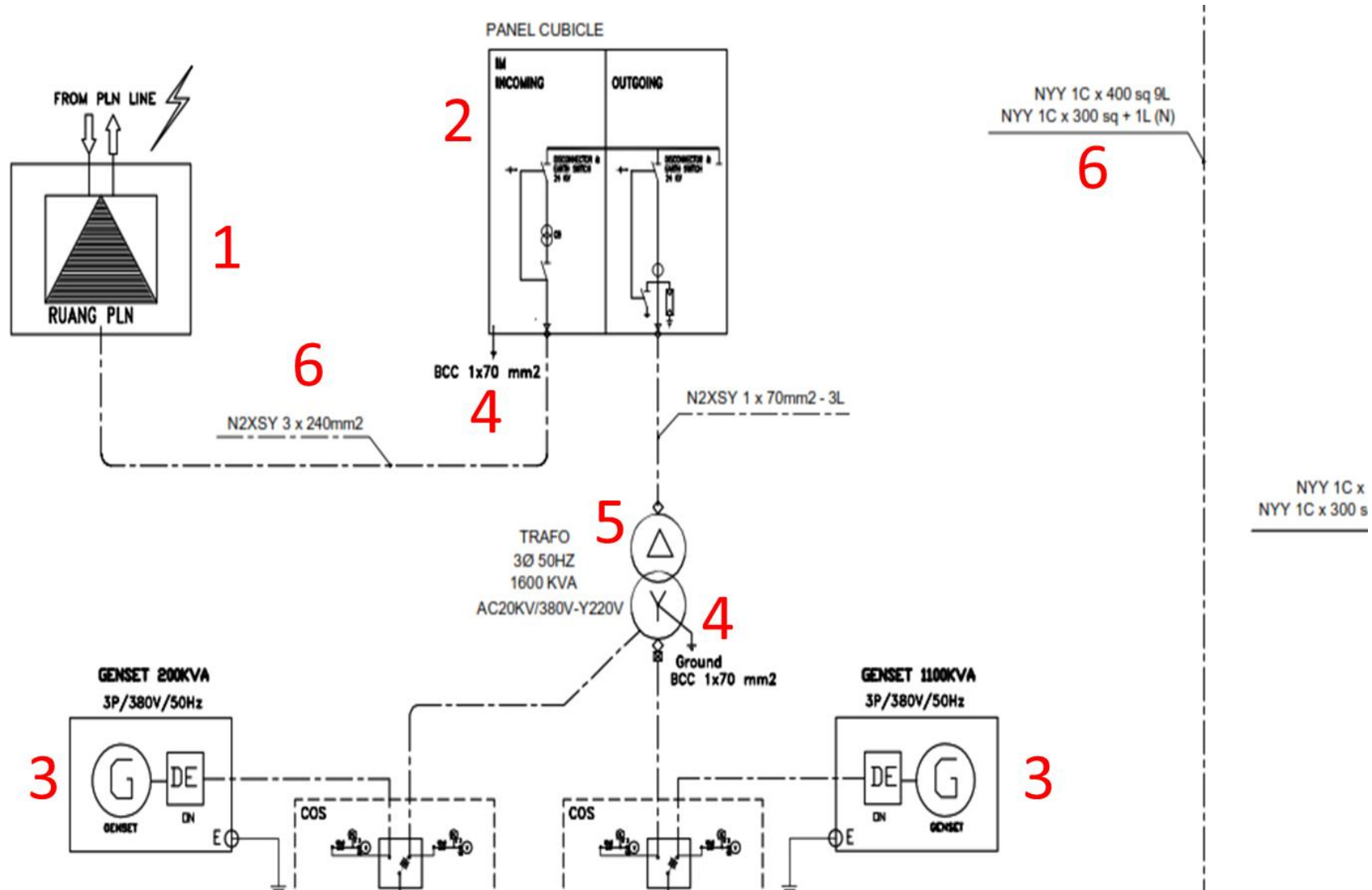

## Common Gaps:

1. No connection from the incoming (PLN).
2. No panel cubicle information.
3. No information about the generator and its specification
4. No grounding cable information
5. No information for voltage rating in the transformer area, and the Transformer specification.
6. No cable information

# Single Line Diagram – Master Plan

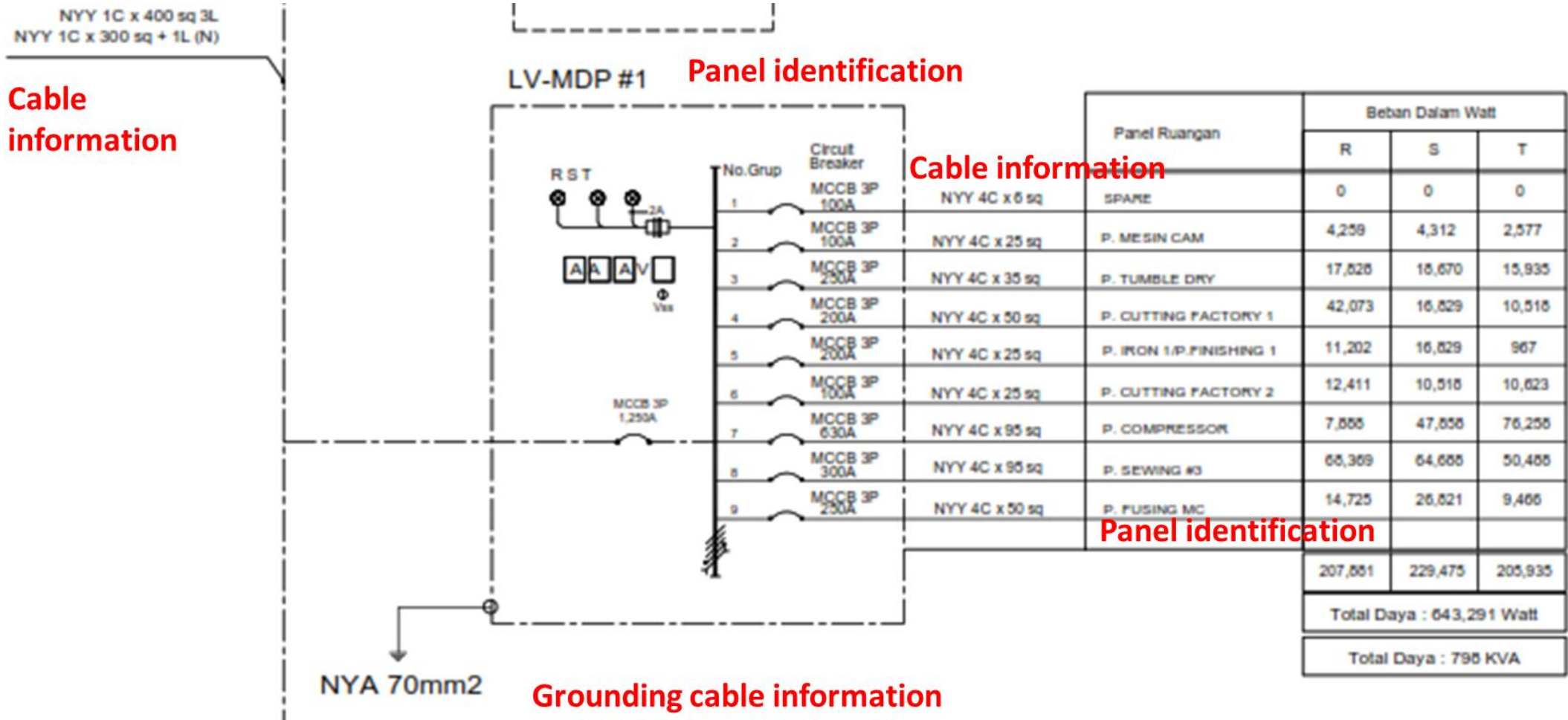

# Single Line Diagram – Master Plan

Circuit breaker information (phases, rating)

Load information

Load capacity for each phase

Phase/Neutral conductor sizes

PE conductor size

DISTRIBUTION BOARD SCHEDULE										
DB-T1-B3										
Dist Board/ Tủ điện :		DB-T1-B3			Location/Vị trí:			Electrical Riser - Basement 3		
Ways/ Tuyến ra :		16								
Submains/ Cấp vào :		4x1C-150mm SQ, Cu XLPE/PVC + 1C-95mm SQ, Cu PVC(E)								
Feeder From/ Nguồn cấp :		MSB-01								
Way Tuyến	Protection Device / Thiết Bị Bảo Vệ				Supplying Area/ Khu vực cấp điện	Load/Tải			Phase / Neutral Conductor Size & Type Loại & Tiết Diện Dây Pha / Trung Tính	Protective Conductor Size & Type Loại & Tiết Diện Dây Tiếp Đất
	Type/Loại	Trip Current/ Dòng cắt (A)	Break. Capacity/ Công suất cắt (kA)	Pole / Số cực		R	Y	B		
						(VA)	(VA)	(VA)		
L1	MCB	16	15	1P	Lighting - Exit and Emergency Lights	26			2x1C-2.5mm SQ, Cu PVC	1C-2.5mm SQ, Cu PVC(E)
L2	MCB	16	15	1P	Lighting - Technical			795	2x1C-2.5mm SQ, Cu PVC	1C-2.5mm SQ, Cu PVC(E)
L3	MCB	16	15	1P	Lighting - Lift Lobby		330		2x1C-2.5mm SQ, Cu PVC	1C-2.5mm SQ, Cu PVC(E)
L4	MCB	16	15	1P	Lighting - Lift Lobby	390			2x1C-2.5mm SQ, Cu PVC	1C-2.5mm SQ, Cu PVC(E)
	MCB	16	15	1P	Spare					
	MCB	16	15	1P	Spare					
S1	MCB+RCCB-30mA	20	15	2P	Socket - Filtration	1,200			2x1C-2.5mm SQ, Cu PVC	1C-2.5mm SQ, Cu PVC(E)
S2	MCB+RCCB-30mA	20	15	2P	Socket - Riser		800		2x1C-2.5mm SQ, Cu PVC	1C-2.5mm SQ, Cu PVC(E)
S3	MCB+RCCB-30mA	20	15	2P	Socket - Cleaners			1,000	2x1C-2.5mm SQ, Cu PVC	1C-2.5mm SQ, Cu PVC(E)
	MCB+RCCB-30mA	20	15	2P	Spare					
P1	MCB	200	25	3P	DB-T1-B3-CARPARK	30,000	30,000	30,000	4x1C-120mm SQ, Cu XLPE/PVC	1C-70mm SQ, Cu PVC(E)
P2	MCB	16	25	3P	DB-T1-B3-1	1,341	1,980	1,320	1x4C-10mm SQ, Cu XLPE/PVC	1C-10mm SQ, Cu PVC(E)
P3	MCB	40	25	3P	DB-T1-B3-2	3,968	3,352	4,052	1x4C-10mm SQ, Cu XLPE/PVC	1C-10mm SQ, Cu PVC(E)
P4	MCB	20	15	2P	Power - FCU		925		2x1C-2.5mm SQ, Cu PVC	1C-2.5mm SQ, Cu PVC(E)
P5	MCB	20	15	2P	Power - EAF	25			2x1C-2.5mm SQ, Cu PVC	1C-2.5mm SQ, Cu PVC(E)
	MCB	20	15	2P	Spare					
<b>Load summary</b>					Connected Load/ Công suất thiết kế (VA)	36950	37387	37167		
					Coincident Coefficient/ Hệ số	0.80	0.80	0.80		
					Spare	10%	10%	10%		
					Diversity Load (VA)	32516	32901	32707		
<b>Main Incoming</b>					Local Current (A)	148	150	149		

Main incoming CB rating (is calculated from the load list above)

# Lightning Protection System - Finding & LABS Requirement

Issue: no LPS (lightning protection system) calculation was available. Based on the location and protection radius of the lightning arrestors, it was found that the southwest section of the production building was not covered by the LPS.

## LABS Standard

**10.36** Lightning Protection System (LPS) refer to NFPA 780

**10.36.1** General: Lightning Protection shall be provided for in accordance with the following:

**10.36.1.1** Protection shall be provided against lightning depending on the probability of a strike and acceptable risk levels. Steps shall be taken for an objective assessment of the risk and of the magnitude of the consequences of lightning strikes following the general principles of IEC 62305-1- 1:2. relevant local or international codes. For local standard SNI 03-7015-2004 and International code use NFPA 780 2023

Why LPS Design is required? To avoid any safety related electrical system such as the fire detection and alarm system affected by the lightning strike.

# Design: Lightning Protection System

PETA ORIENTASI LOKASI

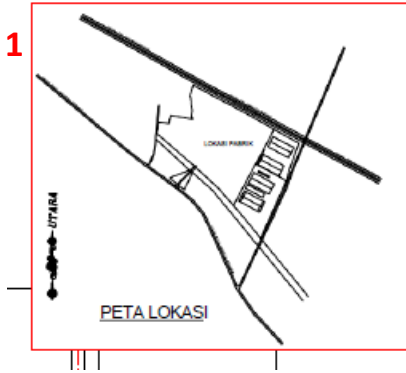

2

MILIK	
LOKASI	
1. BANGUNAN	= 64.294,00m <sup>2</sup> = 36,88%
2. JALAN DANT. PARKIR	= 40.950,00m <sup>2</sup> = 23,48%
3. LAHANTERBUKA	= 69.108,00m <sup>2</sup> = 39,64%
LUASLAHAN	= 174.352,00m <sup>2</sup> = 100,00%

3

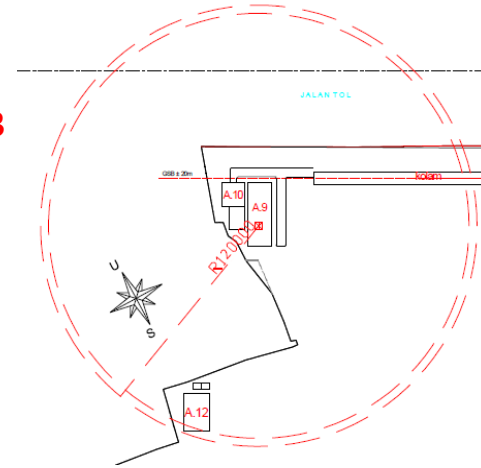

## Basic Requirement for LPS:

1. Factory location and layout.
2. Details of the zones exposed to lightning.
3. Details of the entire building and lightning protection radius
4. Installation detail of Lightning Protection system
  - Location
  - Height
  - Wiring (type, size) and connection
  - Detail Earth pit and earth rod

4

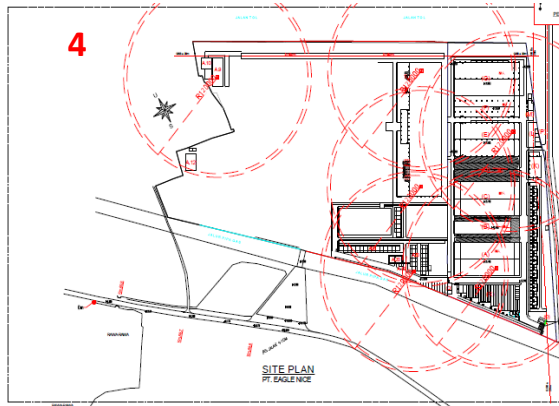

5

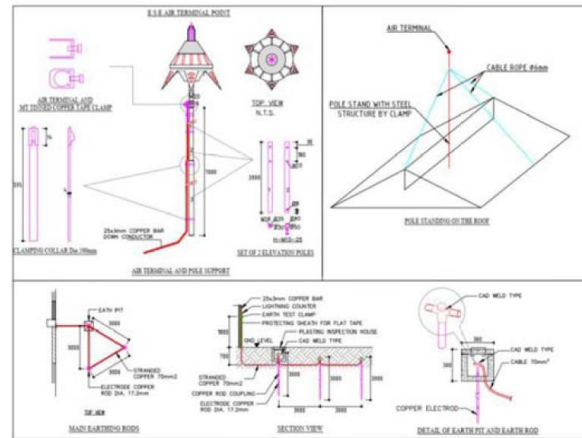

INSTALLATION DETAIL OF LIGHTNING PROTECTION SYSTEM

**Common gaps: Not all buildings covered within the lightning protection radius**

# Oil Soak Pit- Finding & LABS Requirement

Issue: Transformer oil soak pit not provided. Soak pit must be provided for indoor transformer with oil content > 600kg or outdoor transformer with oil content > 1000kg.

## LABS Standard

**10.8.6** Transformer oil soak pit: Soak pit must be provided for indoor transformer with oil content > 600kg or outdoor transformer with oil content > 1000kg. Soak Pits shall be adequately sized to deal with the volume of oil.

Why is Oil Soak Pit design required? Soak Pits absorbed oil leak that can cause fire accident, the design shall be adequately sized **to deal with the volume of oil.**

# Design: Oil Soak Pit

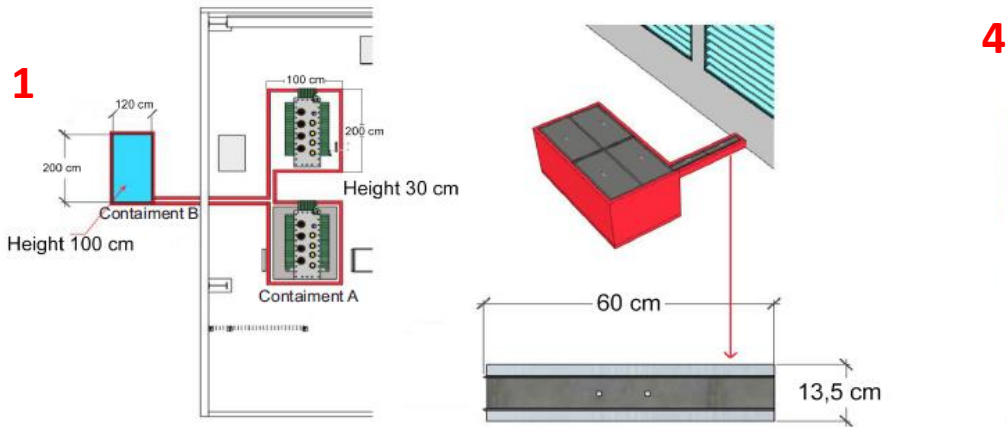

## Basic Requirement for Oil Soak Pit:

1. Details of the dimension of the transformer that require oil soak pit, the gutter, and the oil containment.
2. Calculation of the oil capacity in the transformer(s).
3. Calculation of the oil capacity in the containment(s).
4. Include the transformer's specifications to enable a verification of the calculation's validity.

<p><b>2</b> Capacity TC = 1035 kg          Density based on MSDS = 0,888 g/ml (conversion = 888 Kg/m3)  <math>V T1 = \text{Massa} / \text{Density}</math>  <math>V T1 = 1035 \text{ Kg} / 888 \text{ Kg/m}^3</math>  <math>V T1 = 1,165 \text{ m}^3</math> (conversion to dm3(L))  <math>V T1 = 1,165 \times 1000</math>  <math>V T1 = 1165 \text{ L}</math></p>	<p>Capacity TD = 1210 kg          Density based on MSDS = 0,888 g/ml (conversion = 888 Kg/m3)  <math>V T2 = \text{Massa} / \text{Density}</math>  <math>V T2 = 1210 \text{ Kg} / 888 \text{ Kg/m}^3</math>  <math>V T2 = 1,363 \text{ m}^3</math> (conversion to dm3(L))  <math>V T2 = 1,363 \times 1000</math>  <math>V T2 = 1363 \text{ L}</math></p>
--	---

Total Capacity =  $V TC + V TD$   
 $= 1165 + 1363$   
 $= 2528 \text{ L (add 10\%)}$   
 $= 2528 + 253$   
 $= 2781 \text{ L}$

<p><b>3</b> Containment A  <math>= 100 \times 200 \times 30</math>  <math>= 600,000 \text{ cm}^3</math> (conversion to m3)  <math>= 0.6 \text{ m}^3</math> (conversion to L)  <math>= 600 \text{ L}</math></p>	<p>Containment B  <math>= 120 \times 200 \times 100</math>  <math>= 2,400,000 \text{ cm}^3</math> (conversion to m3)  <math>= 2.4 \text{ m}^3</math> (conversion to L)  <math>= 2400 \text{ L}</math></p>	<p>Total capacity of containment  <math>= \text{containment A} + \text{containment B}</math>  <math>= 600 + 2400</math>  <math>= 3000 \text{ L}</math></p>
--	---	--

**Common gaps: When determining the oil capacity for containment, it can accommodate at less than 110% of the oil volume.**

**Design – Fire Safety**



# Fire Detection System – Finding & LABS Requirement

Issue: Inadequate fire detector coverage, standalone (local) battery type of fire/smoke/heat detector, Incorrect fire detector spacing and placing.

## LABS Standard

**3.7.2.4** Fire Safety Systems design documents should provide, for every floor and roof level, if accessible:

- Design and Specifications for the alarm and fire detection systems
- Single line diagrams and electrical layouts for alarm and fire detection systems
- Location and types of detectors and alarm sounders, visual warning, and voice system components
- Design and Specifications for backup power systems for detection and alarm systems

### **4.12.5** Smoke control

**4.12.5.1** Smoke control required by the engineering analysis in new and existing construction shall be designed in accordance with NFPA 92 (2021).

**5.9.2.2** **Automatic alarm:** A fire alarm system that activates the system alarm(s) and occupant notification devices by automatic initiating devices (e.g., smoke detector, heat detector or sprinkler water-flow).

**5.9.3** **Where required:** Automatic and manual fire alarm and detection systems shall be provided throughout all new and existing buildings, regardless of occupancy type in accordance with NFPA 72 (2022). Initiating devices shall include either smoke or fire detection devices spaced in accordance with NFPA 72 (2022).

Why is Fire Detector design required? Fire Detector ensure the fire preventive system work properly during fire accident, The design shall be adequately sized **to deal with the dimension and capacity/needs of the facility.**

# Design: Fire Detection System

Smoke detectors coverage

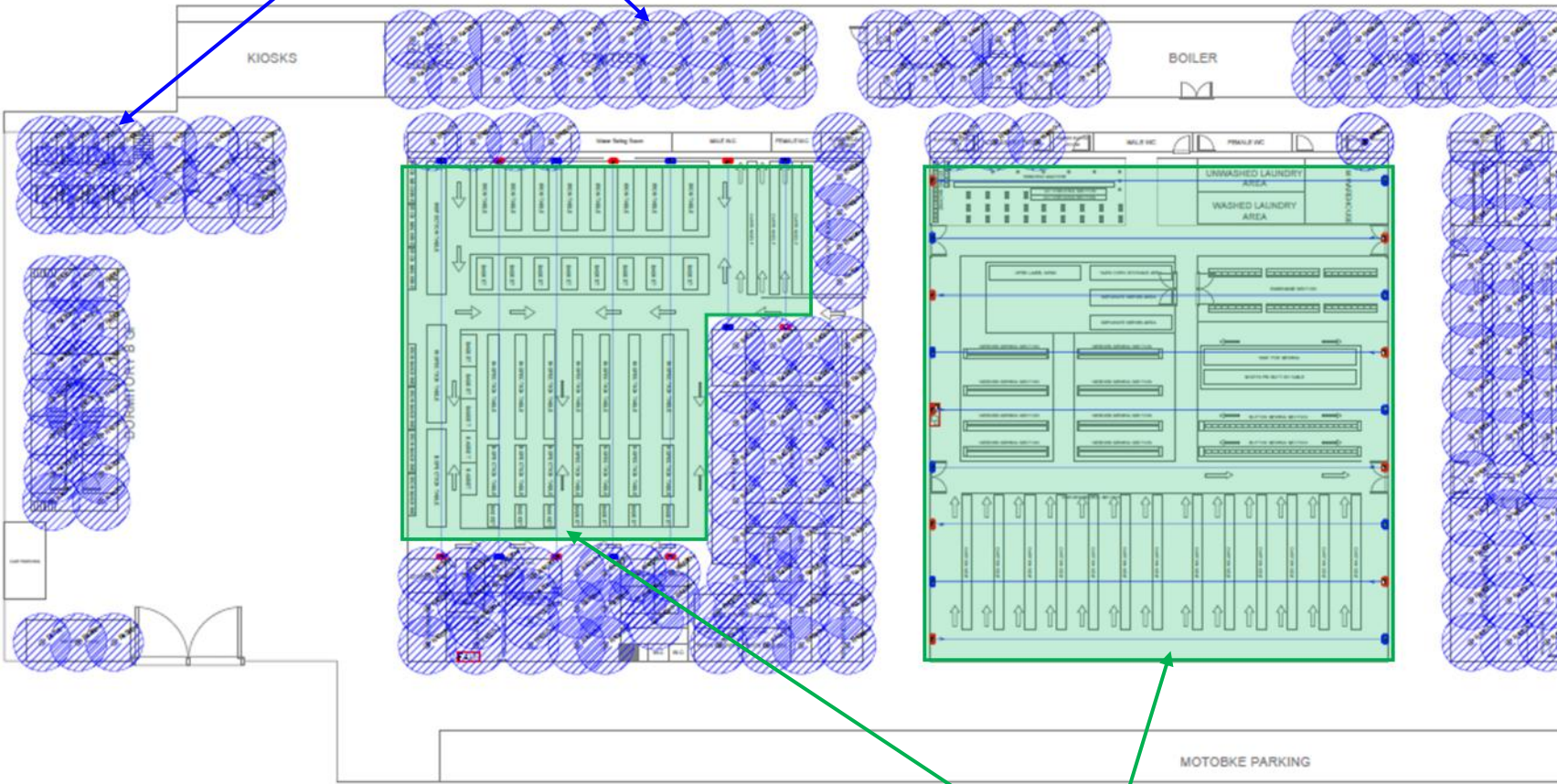

















**Basic Requirement for Fire Detection System:**

Ensure the coverage of the fire detector system is adequate.

Beam detectors coverage

# Design: Fire Detection System

1

Information	
	: Smoke Beam Receiver
	: Smoke Beam Reflector
	: Smoke Detector
	: Fixed Detector
	: Heat Detector
	: Sirene / Bell
	: Lampu Rotari
	: MANUAL CALL POINT
	: Nomor Urut Detector
	: End Of Len
	: Kabel data Twisted 18,16 awg
	: Kabel Instalasi Detector NGA 2x1.5mm
	: Terminal Box Fire Alarm
	: Alarm Bell
	: Manual Push Bottom
	: Lampu/Buzzer

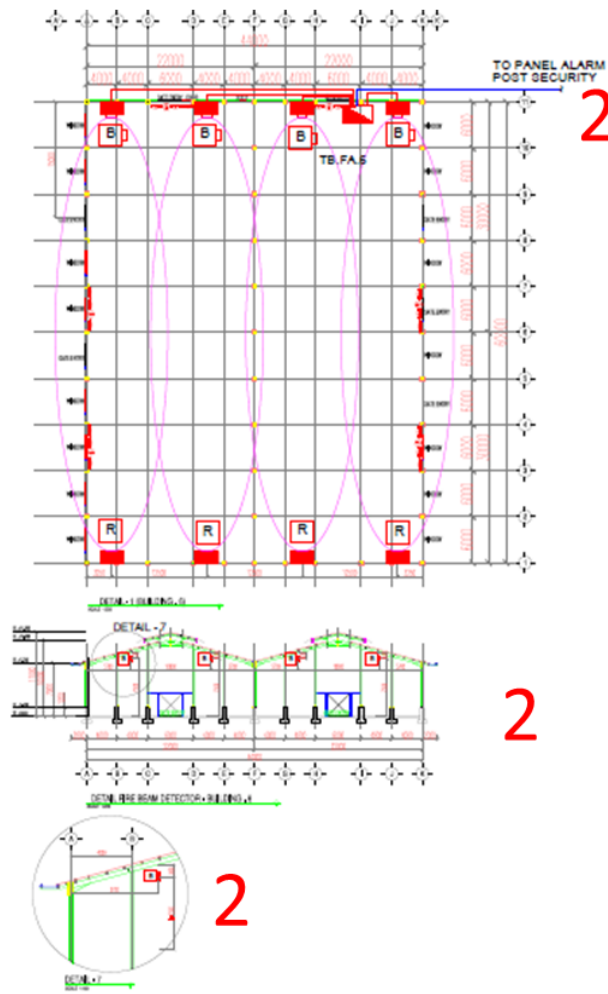

**Basic Requirement for Fire Detection System:**

Detail on the design:

1. Reference Icon is provided.
2. Positions of the fire/smoke detection is provided

# Design: Fire Detection System

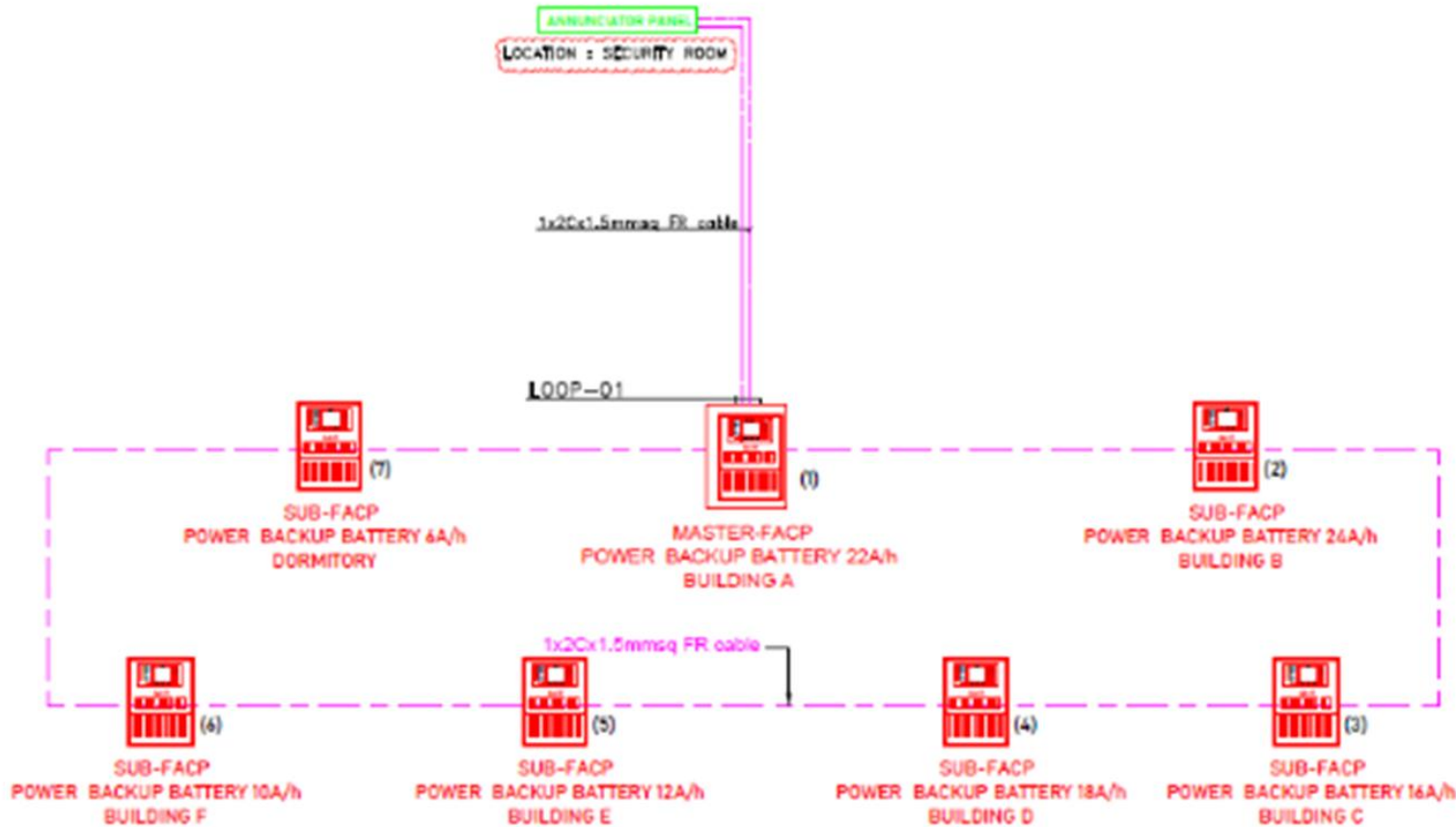

## Basic Requirement for Fire Detection System:

Fire Alarm Panel layout included:

1. All sub-Panel and centralization all panel required (normally should be place in Security room).
2. Battery back-up for each panel information (capacity).
3. Cable information (type and size) FIRE RESISTANCE CABLE is required.

# Design: Fire Detection System

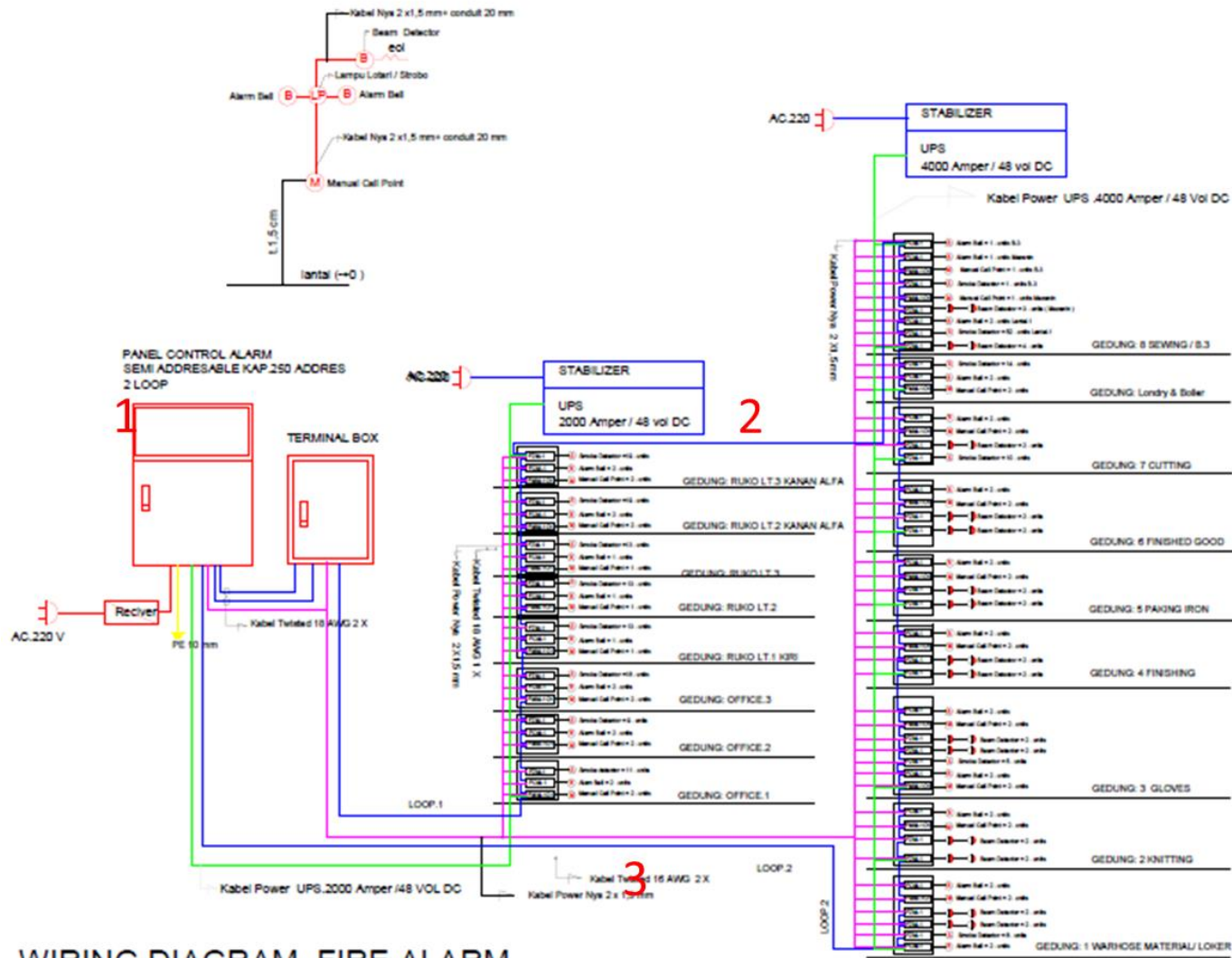

WIRING DIAGRAM FIRE ALARM

## Basic Requirement for Fire Detection System:

A Complete Wiring Diagram for the Fire Alarm:

1. Panel Control Alarm information is provided.
2. UPS Specification is provided.
3. Cable Information is provided.
4. Centralized connection is provided.

# Design: Fire Detection System

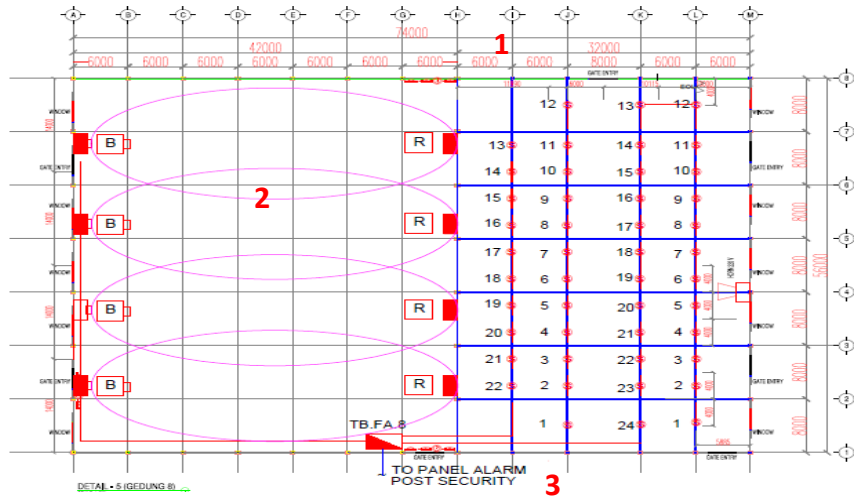

## Common Gaps:

1. Distance each smoke detector is not provided.
2. Coverage area is not circled and provided.
3. Electric connection is not provided.

## Power backup calculation:

1. Power back-up for main control panel and sub-panel should be calculated.
2. Show number of Alarm control unit, detectors, Manual call points and Alarm bell.
3. Standby time more than 24hours and Alarm time more than 15mins are required
4. Safety factor 125%

ITEM	DESCRIPTION	QTY	STANDBY MODE		Total Consumption	Alarm Mode		total Consumption	Spec Alat yang Terpasang
			STANDBY CURRENT (A)	Unit		ALARM CURRENT (A)	Satuan		
<b>Detection Equipment</b>									
1	FACP ADDRESSABLE	1	2.5	Ampere	2.5	2.5		2.5	NOTIFIER NFSZ-260
2	SMOKE DETECTOR	195	0.008	Ampere	1.56	0.008		1.56	SYSTEM SENSOR MODEL.882
3	HEAT DETECTOR	1	0.00008	Ampere	0.00	0.00008		0.00008	CM-WS-19L
4	FIXED DETECTOR	6	0.00008	Ampere	0.00	0.00008		0.00048	CM-WK 200L
5	BEAM DETECTOR	33	0.02	Ampere	0.66	0.02		0.66	EBD01
6	MANUAL CALL POINT	32	0.000012	Ampere	0.00	0.000012		0.000384	HS-FPI
<b>Indication Equipment</b>									
7	Relay 220 V	12				2	Ampere	24	OMRON 24 VOL DC
8	ALARM BELL	49				0.02	Ampere	0.98	
9	HORN	12				0.59	Ampere	7.08	MODEL MS-390
10	LAMPU STROBO	19				0.045	Ampere	0.855	
STANDBY CURRENT (A)					4.72	Alarm CURRENT (A)		37.64	
REQUIRED STANDBY TIME (h)					24	Estimate In Alarm TIME (h)		3.01	
REQUIRED Back up Power					113.30				

# Hydrant System – Findings & LABS Requirement

Issue: Provide internal fire hose reel system, the coverage should be accounted for based on a maximum distance of 45m from the fire hose outlets internal hydrants). Inadequate fire hydrant/wet riser system and no internal fire hose reel system.

## LABS Standard

### 5.5 Standpipe System

**5.5.1 General:** Standpipe shall be designed and installed in accordance with NFPA 14 (2019).

### 5.5.2 Definitions

**5.5.2.1 Class I standpipe system:** Standpipe with 65 mm hose connections for the use by the local fire department and those trained in handling heavy fire streams.

**5.5.2.2 Class II standpipe system:** Standpipe with 40 mm hose connections for use primarily by building occupants or by the fire department during initial response.

**5.5.2.3 Class III standpipe system:** Standpipe with both 65 mm hose connections for fire department use and 40 mm hose connections for trained staff/building occupants.

**5.5.3 Where required:** Standpipe shall be provided as per the local standards or otherwise as per clause 5.5.3.1 in this Standard.

**5.5.3.1 Class I standpipe systems:** In accordance with NFPA 5000 (2021) clause 55.4.1, shall be provided throughout all new buildings and structures where any of the following exist:

- (1) The building is protected by an approved automatic sprinkler system and is four or more stories in height above grade plane.
- (2) The building is not protected by an approved automatic sprinkler system and is three or more stories in height above grade plane.
- (3) The building is more than 15 m above grade plane and contains intermediate stories or balconies.
- (4) The building is more than one story below grade plane.
- (5) The building is more than 6.1m below grade plane.

### 5.5.4 Water demand

**5.5.4.1 Flow Pressure:** [See NFPA 14 (2019) Section 7.8.] Hydraulically designed standpipe systems shall be designed to provide the required waterflow rate at a minimum residual pressure of 100 psi (6.9 bar) at the outlet of the hydraulically most remote 2.5 in. (65 mm) hose connection and 65 psi (4.5 bar) at the outlet of the hydraulically most remote 1.5 in. (40 mm) hose station.

**5.5.4.2 Flow Rates:** [See NFPA 14 (2019) Section 7.10] The maximum flow rate shall be 1000 gpm (3785 L/min) for buildings that are sprinklered throughout, and 1250 gpm (4731 L/min) for buildings that are not sprinklered throughout. The minimum flow rate shall be:

### 5.6 Fire Hose Systems

**5.6.1 General:** Fire hose systems shall be designed and installed in accordance with NFPA 14 (2019).

**5.6.2 Where required:** Fire hoses and internal hydrants are required so that they provide coverage to all areas within all Ready-made Garment, Apparel, Footwear, Bags, Accessories and Home-textiles factories, except:

- (1) Those areas use or store materials which when contacting with water can cause fire, explosion and spreading flame.
- (2) Public bathrooms and laundries.
- (3) Warehouses made of non-flammable materials store non-flammable materials.
- (4) Buildings and annexes of buildings where there are no domestic or production water supply pipes and the exterior firefighting water can be taken from an external reservoir, river or lake.

**5.6.3 Number and location:** the interior firefighting hydrants shall be located in an easily accessible location in proximity of the escape routes from the building (e.g., at the stair landings, halls, corridors, lobbies, etc.) Every point in the building should be covered by at least one hydrant, except those where coverage is allowed to be omitted as listed in 5.6.2 in this Standard. The coverage should be accounted for based on a maximum distance of 45m from the fire hose outlets (internal hydrants), based on the provision of two hoses 30m long in each cabinet.

### 5.14 Emergency power

**5.14.1** An emergency power system shall be provided to supply power to the below loads. Refer to Part 10 of this Standard for greater detail:

5.14.1.1 Exit signs and means of escape illumination.

5.14.1.2 Automatic fire Alarm and detection systems.

5.14.1.3 Security System (Access Control, Public Address System, CCTV System)

5.14.1.4 **Electrically powered fire pumps.**

5.14.1.5 Smoke control systems.

5.14.1.6 Elevators/lifts and any other evacuation systems.

5.14.1.7 Fire communication devices.

5.14.1.8 Building Management System (If any)

# Design: Hydrant System

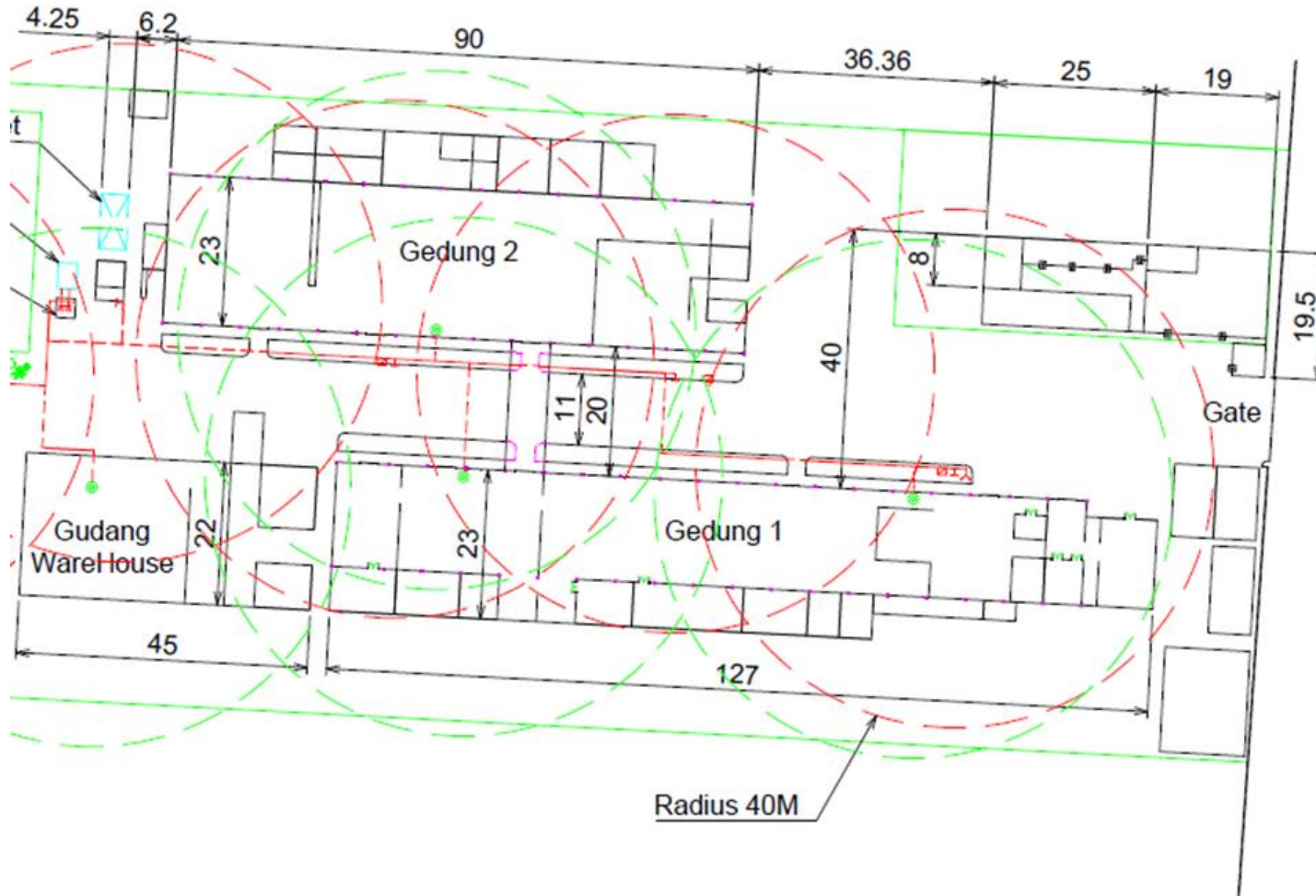

\* Why is Hydrant Design required? To make the remediation action align with the LABS standard, and to avoid excessive cost due to failure and mistake in installation.

## Basic Requirement for Fire Detection System:

1. Ensure the pump set is adequate
  - a) Without Sprinkler (500 gpm)
  - b) With Sprinkler (750 gpm)
2. Calculation of the water tank for 30 minutes standby (i.e.  $500 \text{ gpm} \times 30 \text{ minutes} = 15000 \text{ gallons}$  ( $56.8 \text{ m}^3$ ))
3. Ensure the coverage of the hydrant is adequate

# Design: Hydrant System

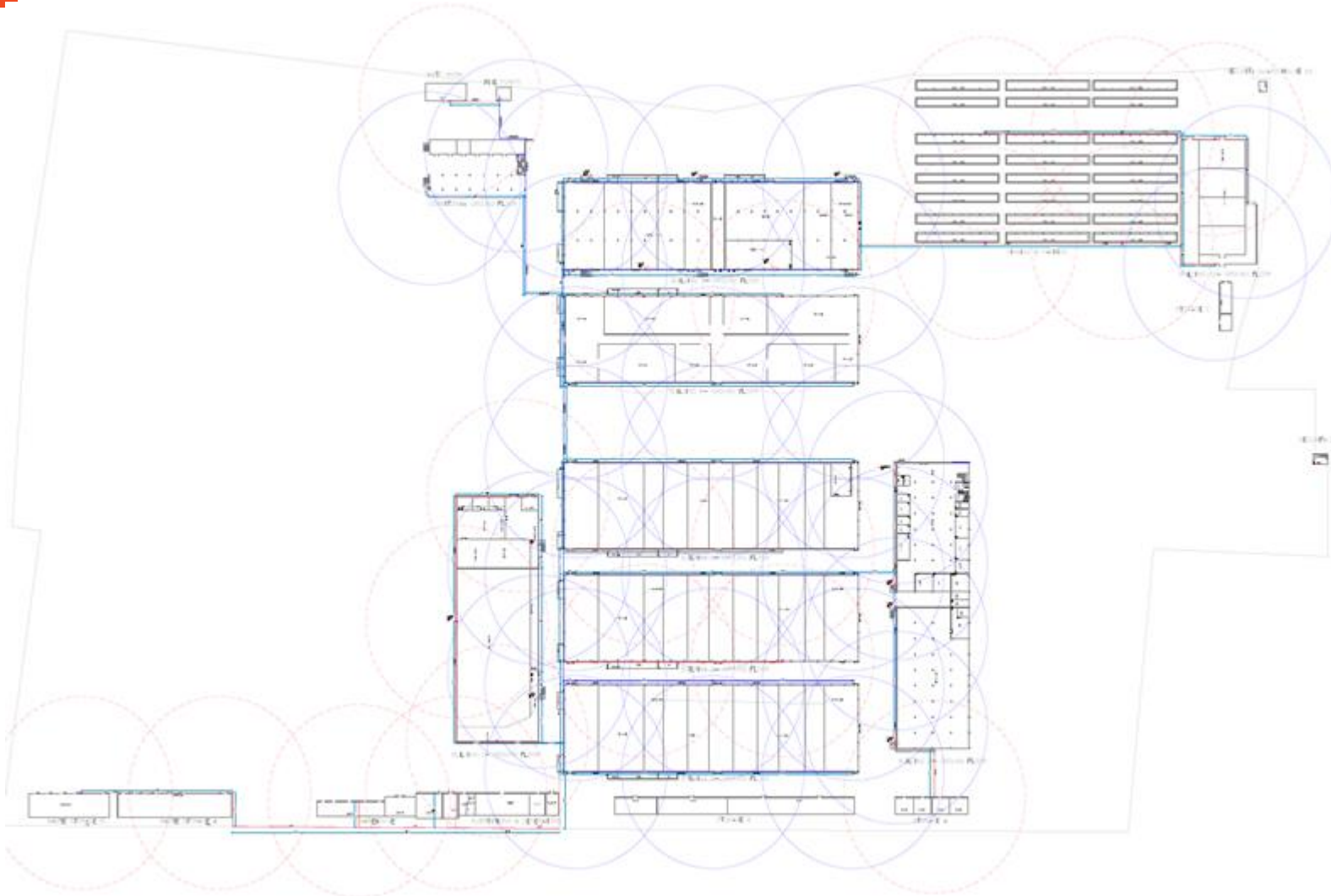

The **Fire Hoses Floor plan** show coverage zone of Fire Hoses system, which consists of following elements:

1. Location and type of Fire hoses
2. Coverage zone fulfil all required location

Base on type and length of Hose Reel.  
The protection radius from 15 meter but not more than 45 meter.

\*coverage of 45 meter based on the provision of two hoses 30m long in each cabinet otherwise the coverage should be reduced.

\*Consider to cover inside and outside of the building. All location should be cover by hose reel protection area.

=> Define number of hose reel and location of most remote .

# Design: Hydrant System

Define piping layout follow building layout and structure element to define pipe length and elevation

Follow defined specification in step 1:

- Minimum flow rate **379l/min (class II)** and **946;/min (class I)** for most remote hoses
- Minimum pressure **4.5 bar (class II)** and **6.9 bar(class I)** for most remote hoses

Make sure that the design include:

- Isometric drawing
- Hydraulic calculation to determine the flow rate and pressure to compare to minimum flow rate and pressure.
- Water storage and fire pump data to meet design criteria.
- Pumps room details with accessories

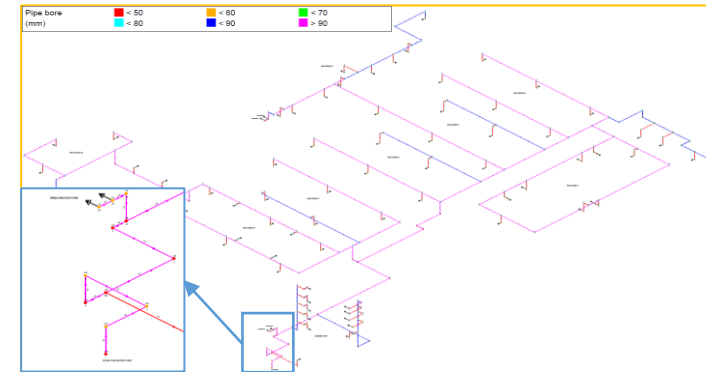
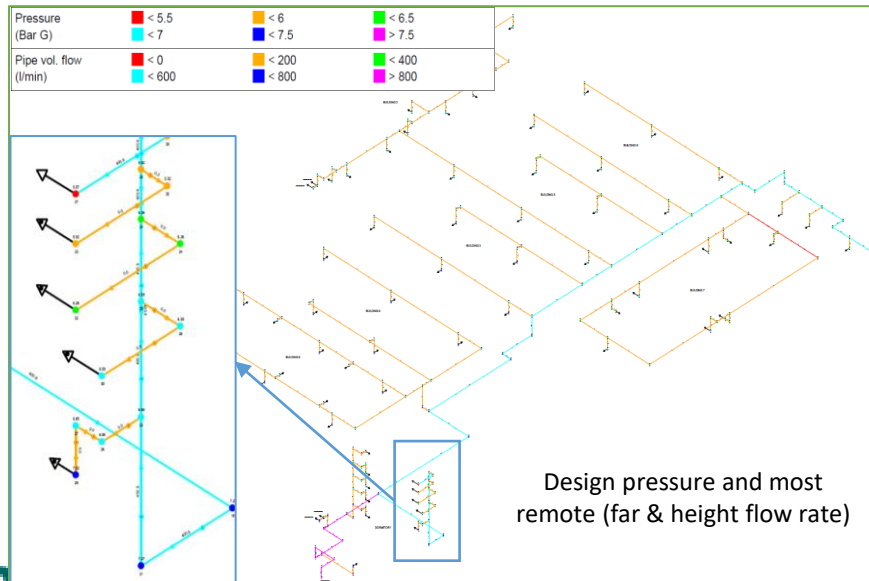
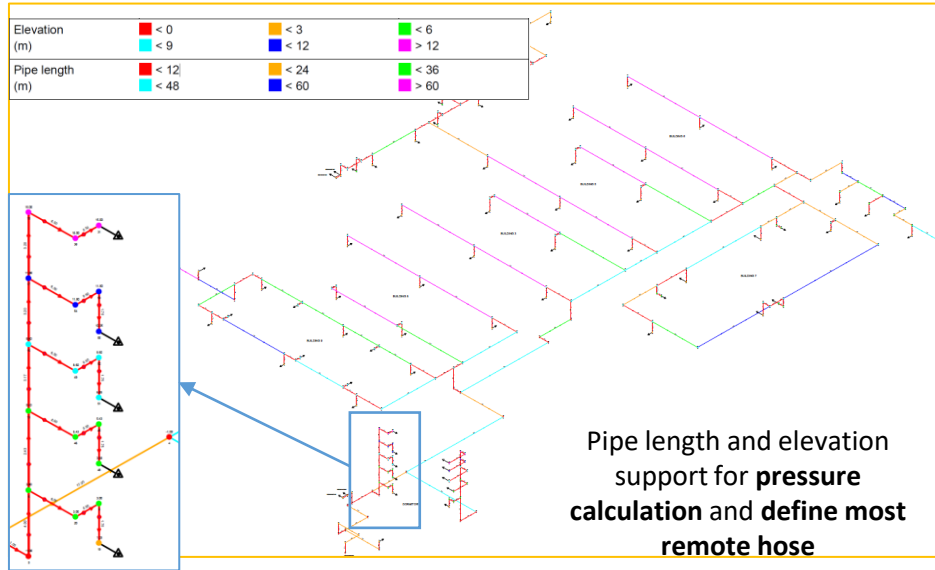

Pipe size, and material:

- Support for flowrate and pressure calculation

# Pump & Water Tank Specification

NODE ANALYSIS					
Node tag	Elevation (m)	Node Type	Pressure (Bar G)	Discharge (l/min)	Notes
1	-2.70	INPUT	8.000		
2	0.30		7.697		
3	-1.00		7.606		
4	-1.00		7.422		
5	-1.00		7.495		
6	3.00		7.103		
7	15.00		5.581		
8	3.00		7.103		
9	-1.00		7.559		
10	15.00		5.929		
11	0.30		7.648		
12	0.30		7.589		
13	5.43		6.866		
14	-1.00		7.701		
15	-1.00		7.495		
16	8.60		6.555		
17	11.80		6.242		
18	-1.00		7.289		
19	1.25	HYDRANT	7.275	0.000	Hydrant label: 1, K-Factor: 178
20	3.00		7.103		
21	-1.00		7.273		
22	3.00		6.854		

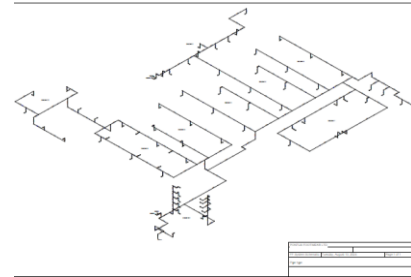

Piping layout, floor plan and coverage drawing and installation specification

Calculation result adapted with LABS requirements

27	3.00		6.854		
28	5.43		6.593		
29	1.25	HYDRANT	7.025	0.000	Hydrant label: 2, K-Factor: 178
30	5.43	HYDRANT	6.593	0.000	Hydrant label: 3, K-Factor: 178
31	15.00	HYDRANT	5.929	0.000	Hydrant label: 6, K-Factor: 178
32	8.60	HYDRANT	6.258	0.000	Hydrant label: 4, K-Factor: 178
33	11.80	HYDRANT	5.919	0.000	Hydrant label: 5, K-Factor: 178
34	8.60		6.258		
35	11.80		5.919		
36	0.00		7.099		
37	15.00	HYDRANT	5.073	400.924	Hydrant label: 7, K-Factor: 178
38	15.00		5.929		
39	15.00		5.567		
40	6.00		6.511		
41	5.05	HYDRANT	6.604	0.000	Hydrant label: 8, K-Factor: 178
42	6.00		6.511		
43	5.43		6.866		
44	5.43		6.866		
45	5.43		6.866		
46	5.43		6.866		
47	3.66	HYDRANT	7.037	0.000	Hydrant label: 11, K-Factor: 178

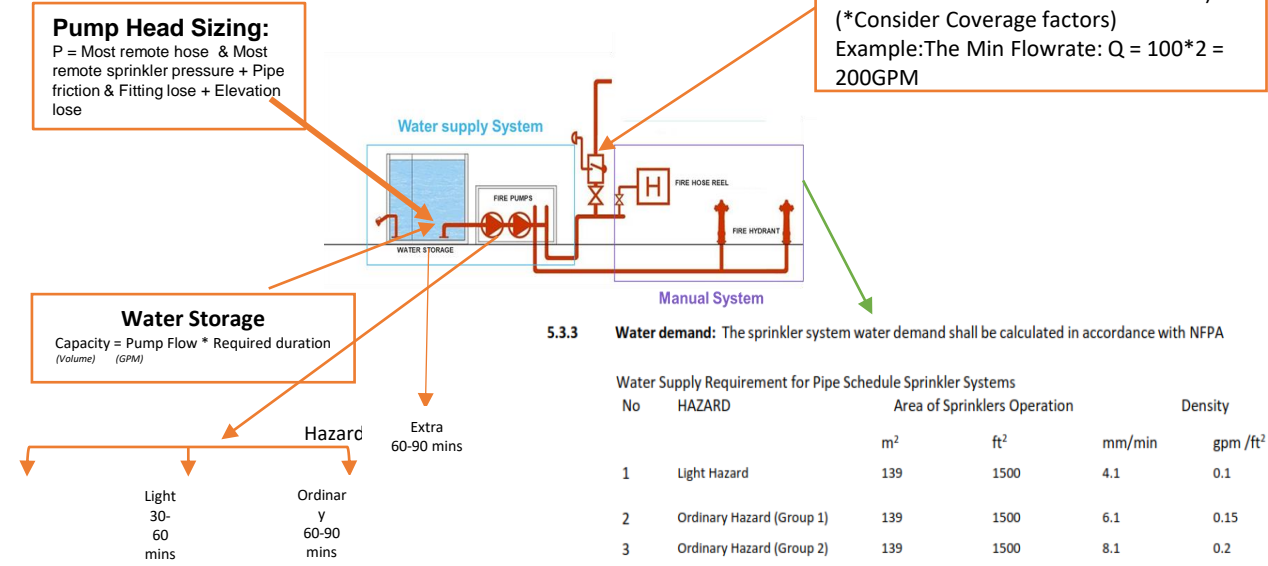
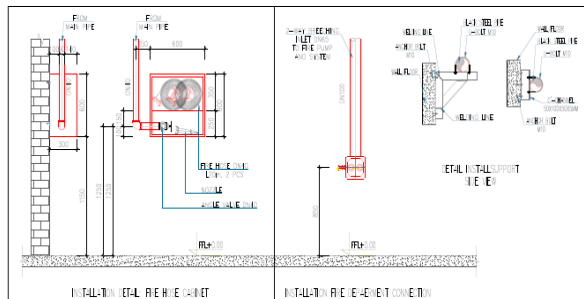

**Pump discharge sizing:**  
 Flow hoses (Depended on number of fire hoses need to active at the same time)  
 (\*Consider Coverage factors)  
 Example: The Min Flowrate:  $Q = 100 * 2 = 200\text{GPM}$

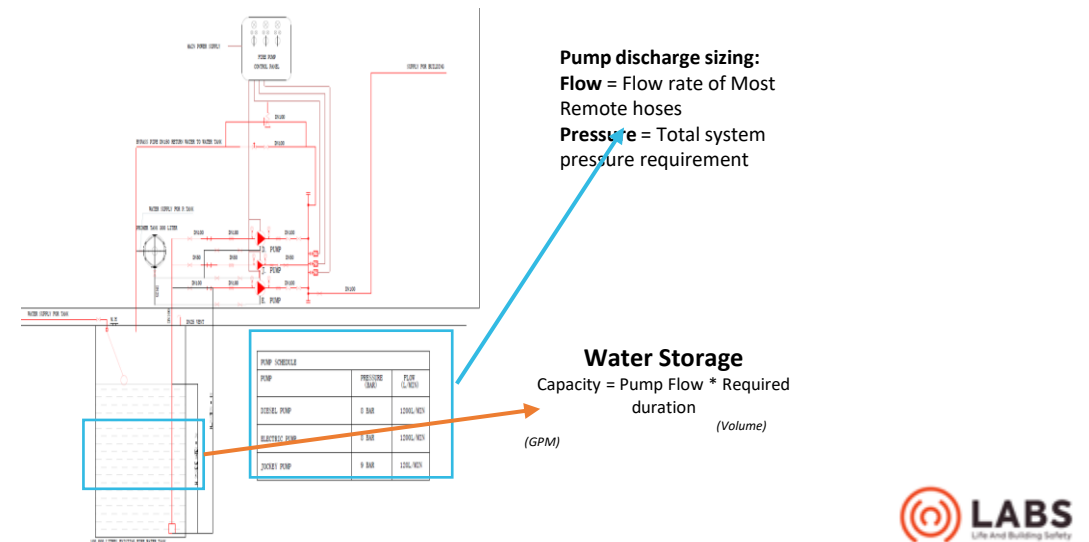

# Sprinkler System - Findings & LABS Requirement

Issue: Sprinklers coverage area is inadequate in storage area. Sprinkler installed far below ceiling from 1.23m-5.3m.

## LABS Standard

**5.3.2.1 New Construction:** Sprinklers shall be provided in accordance with the allowable building height and area limitations as indicated in the Standard, **and in addition** the following shall also be sprinklered throughout:  
**New Industrial Occupancies:** New industrial occupancies, other than low-hazard industrial occupancies, shall be protected by an approved automatic sprinkler system in accordance with NFPA 13 in any of the following locations:

- (1) Throughout all industrial occupancies three or more stories in height
- (2) Throughout all industrial occupancies exceeding 12,000 ft<sup>2</sup> (1115 m<sup>2</sup>) in free area
- (3) Where the total area of all floors, including mezzanines, exceeds 24,000 ft<sup>2</sup> (2230 m<sup>2</sup>)

**5.3.2.2 Existing Construction:** Sprinklers shall be retrofitted to existing construction where the following applies:

- (1) High-rise buildings
- (2) For buildings with fire-rated structures where required as per clause 3.12.3.2 (and Table 3.12.3) in this Standard.
- (3) In existing buildings with non-fire-rated structures, automatic sprinkler protection shall be provided throughout where the building is more than 2 stories in height and the built area exceeds 2,000 m<sup>2</sup> per floor.

**5.3.3 Water demand:** The sprinkler system water demand shall be calculated in accordance with NFPA

Water Supply Requirement for Pipe Schedule Sprinkler Systems

No	HAZARD	Area of Sprinklers Operation		Density	
		m <sup>2</sup>	ft <sup>2</sup>	mm/min	gpm /ft <sup>2</sup>
1	Light Hazard	139	1500	4.1	0.1
2	Ordinary Hazard (Group 1)	139	1500	6.1	0.15
3	Ordinary Hazard (Group 2)	139	1500	8.1	0.2
4	Extra Hazard (Group 1)	232	2500	12.2	0.3
5	Extra Hazard (Group 2)	232	2500	16.3	0.4

Why is Sprinkler Design required? To make the remediation action align with the LABS standard, and to avoid excessive cost due to failure and mistake in installation.

# Design: Sprinkler System

Occupancy Classification	Class II
Area of application	Building A=4800 <sup>3</sup> , Building B=4800m <sup>2</sup> , Building C=4800m <sup>2</sup> , Building D=4800m <sup>2</sup> , Office = 1722m <sup>2</sup> , Rear Canteen =2200m <sup>2</sup>
Flow rate requirement	<ul style="list-style-type: none"> <li>+ Sprinkler System ( Ordinary Hazard Group 2)</li> <li>- Density: 8.2 mm/min and 140 m2 (Figure 19.3.3.1.1 in NFPA 13)</li> <li>- Flow rate required for sprinkler= 8.2 mm/min x 140 m2 = 1148 L/min</li> <li>+ Indoor hydrants (Table 19.3.3.1.2 in NFPA13)</li> <li>- Inside hose = 379 L/min</li> <li>+ Total Flow rate requirement</li> <li>- Total flow rate = 1148 L/min + 379 L/min = 1527 L/min</li> </ul>
Duration of operation	60 mins
Minimum pressure require	4.5 bar for indoor hose (LABS Standard 5.5.4.1) 0.5 bar (7 PSI) for each sprinkler head (clause 19.3.3.4.3 in NFPA13)

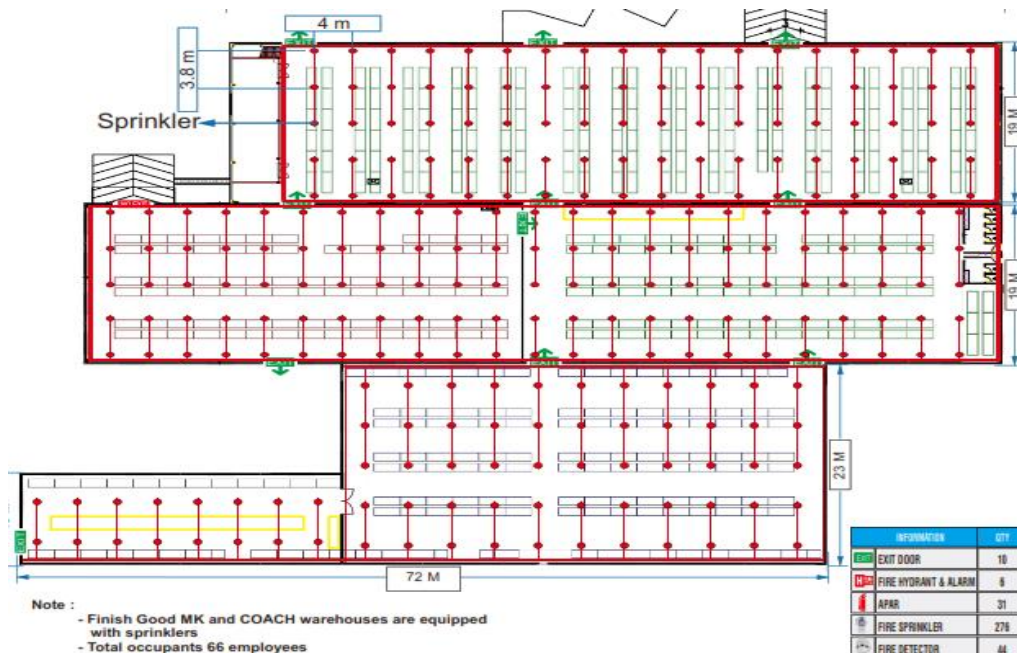

## System Design:

- **Type of System:** Choose the appropriate type of sprinkler system based on the building's use, climate, and specific fire risks.
- **Design Density and Area:** Determine the design density (amount of water applied per unit area) and the area of coverage based on the occupancy classification and hazard level (e.g., light hazard, ordinary hazard, extra hazard) **refer on LABS Standard 5.3 - NFPA 13.**

## Basic Requirement for Sprinkler System:

- **Spacing:** Sprinkler heads should be spaced according to LABS Standard 5.3 - NFPA 13 guidelines, which vary based on the type of sprinkler, hazard classification, and room configuration.
- **Coverage:** Each sprinkler head should cover a specific area, ensuring there are no gaps in coverage.
- **Obstructions:** Avoid placing sprinkler heads where obstructions might block the spray pattern, such as beams, shelves, or other structures.
- **Location:** Standard Spray Sprinklers: These are typically installed near the ceiling, with a deflector distance of 1 to 12 inches (2.5 – 35cm) below the ceiling.

## Special Considerations

- **Ceiling Height:** The maximum ceiling height for standard spray sprinklers in light and ordinary hazard occupancies is 14 feet (4.3 meters). For higher ceilings, extended coverage sprinklers or other modifications may be necessary.
- **Obstructions:** Proper clearance from obstructions such as beams, lighting fixtures, and structural elements must be maintained to ensure adequate water distribution.
- **Sloped Ceilings:** For sloped ceilings, special spacing rules apply to ensure adequate coverage.
- **Residential Sprinklers:** These typically have different spacing requirements. For example, residential sprinklers may cover up to 144 square feet (13.4 square meters) per sprinkler with a maximum spacing of 12 feet (3.7 meters) between heads.

# Combining Sprinkler and Fire Hydrant

**Pump Head Sizing:**  
 $P = \text{Most remote hose} + \text{Most remote sprinkler pressure} + \text{Pipe friction} + \text{Fitting lose} + \text{Elevation lose}$

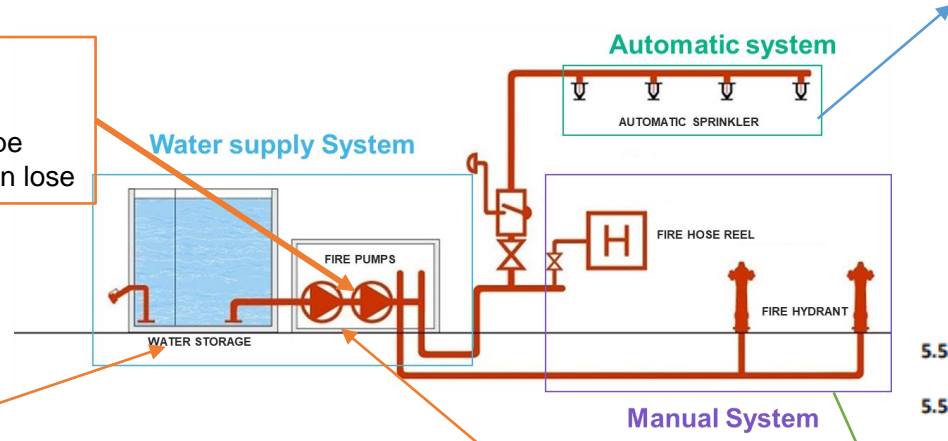

**Water Storage**  
 $\text{Capacity} = \text{Pump Flow} * \text{Required duration}$   
 (Volume) (GPM)



**Pump discharge sizing:**  
 Flow rate of sprinkler + Flow hoses  
 (Depended on number of fire hoses need to active at the same time)  
 (\*Consider Coverage factors)  
 Example: 20 sprinklers active at the same time and 2 hoses. The Min Flowrate:  $Q = 416 \text{ GPM} + 100 * 2 = 616 \text{ GPM} \sim 2332 \text{ L/min}$

**5.3.3 Water demand:** The sprinkler system water demand shall be calculated in accordance with NFPA

Water Supply Requirement for Pipe Schedule Sprinkler Systems

No	HAZARD	Area of Sprinklers Operation		Density	
		m <sup>2</sup>	ft <sup>2</sup>	mm/min	gpm /ft <sup>2</sup>
1	Light Hazard	139	1500	4.1	0.1
2	Ordinary Hazard (Group 1)	139	1500	6.1	0.15
3	Ordinary Hazard (Group 2)	139	1500	8.1	0.2
4	Extra Hazard (Group 1)	232	2500	12.2	0.3
5	Extra Hazard (Group 2)	232	2500	16.3	0.4

**5.5.4 Water demand**

**5.5.4.1 Flow Pressure:** [See NFPA 14 (2019) Section 7.8.] Hydraulically designed standpipe systems shall be designed to provide the required waterflow rate at a minimum residual pressure of 100 psi (6.9 bar) at the outlet of the hydraulically most remote 2.5 in. (65 mm) hose connection and 65 psi (4.5 bar) at the outlet of the hydraulically most remote 1.5 in. (40 mm) hose station.

**5.5.4.2 Flow Rates:** [See NFPA 14 (2019) Section 7.10]  
 The maximum flow rate shall be 1000 gpm (3785 L/min) for buildings that are sprinklered throughout, and 1250 gpm (4731 L/min) for buildings that are not sprinklered throughout. The minimum flow rate shall be:  
 (1) Class I and Class III systems: 500 gpm (1893 L/min) for the hydraulically most remote standpipe, through the two most remote 2.5 in. (65 mm) outlets.  
 (2) Class II systems: 100 gpm (379 L/min) for the hydraulically most remote hose connection.

**5.5.4.3 Flow Duration.** [See NFPA 14 (2019) Section 9.2] The water supply shall be capable of providing the required demand for at least 30 minutes.

**Note:** In accordance with NFPA 13 (2022) clause 11.1.6.3.1, where the standpipe water demand is less than the sprinkler water demand, the water tank size calculated for the sprinkler water supply alone can accommodate the standpipe system supply with no need for additional water storage.

**5.5.5 Installation requirements:** The design, installation and maintenance of the standpipe systems shall be in accordance with NFPA 14, including a minimum pressure of 450 kPa (65 psi) at the hydraulically most remote hose connection.

**Design – Structural Safety**



# Visible Distress in Structural Member – Finding & LABS Requirement

Issue: The factory needs to provide loading maps and maximum capacity for the mezzanine.

## LABS Standard

- 8.5.1 If the Preliminary Structural Safety inspection indicates areas of structural concern, distressed, damaged or distorted structural members, lack of verifiable documents or other lack of compliance with the requirements of this Standard, then more detailed structural investigation or assessment shall be required. A more detailed structural assessment/capacity check shall be performed where this has been identified. Reasons for this would include apparently non-engineered additions to the original structure, distress or damage in a structural member which may impact its structural capacity or where the strength of the original structural material is questionable.
- 8.5.2 To accomplish this, the Factory Owner shall engage a Qualified Structural Engineering Consultant (QSEC) that meets the qualifications established by LABS to provide structural advisory services to prepare all required design confirmation and structural documentation.
- 8.5.3 If required, the QSEC shall prepare as-built structural documents as described in Section 8.20.5.
- 8.5.4 If required, the QSEC shall prepare Factory Safe Load Plans as described in Section 8.10.
- 8.5.5 If required, the QSEC shall conduct additional detailed structural condition assessments and investigations to determine the adequacy of specific structural elements, distressed structural members, or other conditions identified in the Preliminary Structural Safety Inspection.
  - 8.5.5.1 In this case, the QSEC shall state assumptions regarding the strength and properties of key construction materials. Unless confirmed otherwise by testing of in-situ conditions in accordance with applicable SNI or ASTM test procedures, the QSEC shall determine the material properties using Section 7.2.
  - 8.5.5.2 Where required, for determination of in-situ concrete strength, ACI 214 and 562 shall be used in conjunction with concrete core tests. Non-destructive methods may be applied where there is documented calibration of these methods in the relevant country.
  - 8.5.5.3 For the detailed assessment, all concrete reinforcement shall be determined from use of rebar scanning equipment.
  - 8.5.5.4 Where required, for determination of structural steel strength, SNI 1729-2020 or AISC 360-16 shall be used.

Why is Loading Map Design required? To avoid any structural safety related issue, such as visible distress occurred in the future, and to avoid overloading that can lead to structural failure.

# Design: Loading Map

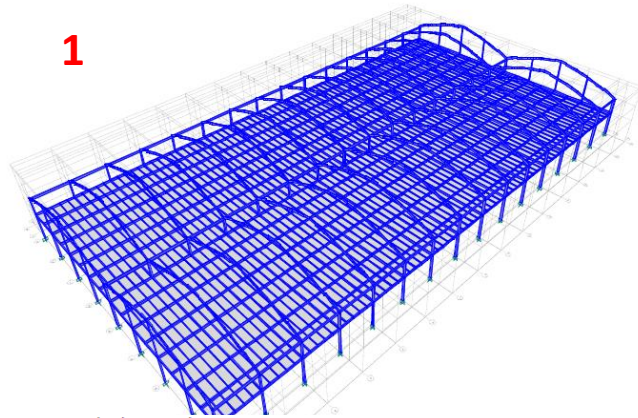

3

The results of this structural analysis have met the analysis requirements criteria, according to the table which is attached below:

No	Members	BJ37	Stress Ratio	Limitation	Status
1	C1 : WF - 600	WF600*200*9*14	+0.898	> 1.0	OK
2	C2 : WF - 588	WF588*300*10*16	+0.422	> 1.0	OK
3	C3 : HB - 300	WF300*300*12*20	+0.963	> 1.0	OK
4	B1 - B3	HC600*200*8*13	+0.095	> 1.0	OK
5	B4 : HC250	HC250*125*6*9	+0.475	> 1.0	OK
6	SC1 : WF 250	WF250*125*6*9	+0.848	> 1.0	OK
7	PR : CNP200	CNP200*75*20*3.2	+0.787	> 1.0	OK

For the [ ] structure according to the running results, the permit ratio/limit is ADEQUATE (OK)

Note: If the structure is not adequate in serviceability limit (i.e. the floor shakes when walked on), strengthening must be done accordingly

Basic Requirement for Loading Map:

1. Structure model
2. Material properties & loading
3. The structural capacity adequacy
4. The loading map based on analysis

2

- a. Material Volume Weight
- Reinforced Concrete = 2400 kg/m<sup>3</sup>
  - Steel = 7850 kg/m<sup>3</sup>
  - Soil = according to the results of the soil investigation
- b. Material Quality
- Concrete f'c = 24.90 MPa (K-300)
  - Plain Reinforcing Steel fy = 280 MPa (BJTP-280)
  - Threaded Reinforcing Steel fy = 420 MPa (BJTS-420A)
  - Steel Profile fy = 245 MPa (SS 400)/BJ37
  - Steel plate (Mild Steel) fy = 245 MPa (ASTM A53/ST 37)
  - Bolts and Nuts fy = 800 MPa (HTB A325 gr. 8.8)
  - Anchor fy = 240 MPa (ASTM A307)
- c. Modulus of Elasticity and Shear Modulus
- Ice Steel Es = 2 x 10<sup>5</sup> MPa
  - Concrete Ec = 4700 √f'c Mpa

Dead Load	
Self weight of structure	By software (ETABS) 18.0.2
IF Weight of floor and finishing	50 Kg/m <sup>2</sup>
IF Weight of plafon	25 Kg/m <sup>2</sup>
IF Weight of ME equipment	10 Kg/m <sup>2</sup>
IF Weight of wall	250 Kg/m <sup>1</sup>
Live Load	
IF Live load elevasi Lantai.2	1220 Kg/m <sup>2</sup>
Material Properties	
C1 : WF - 600	WF600*200*9*14 Elevation st ' dst
C2 : WF - 588	WF588*300*10*16 Elevation st ' dst
C3 : HB - 300	WF300*300*12*20 Elevation st ' dst
B1 - B3	HC600*200*8*13 Elevation st ' dst
B4 : HC250	HC250*125*6*9 Elevation st ' dst
SC1 : WF 250	WF250*125*6*9 Elevation st ' dst
PR : CNP200	CNP200*75*20*3.2 Elevation st ' dst

4

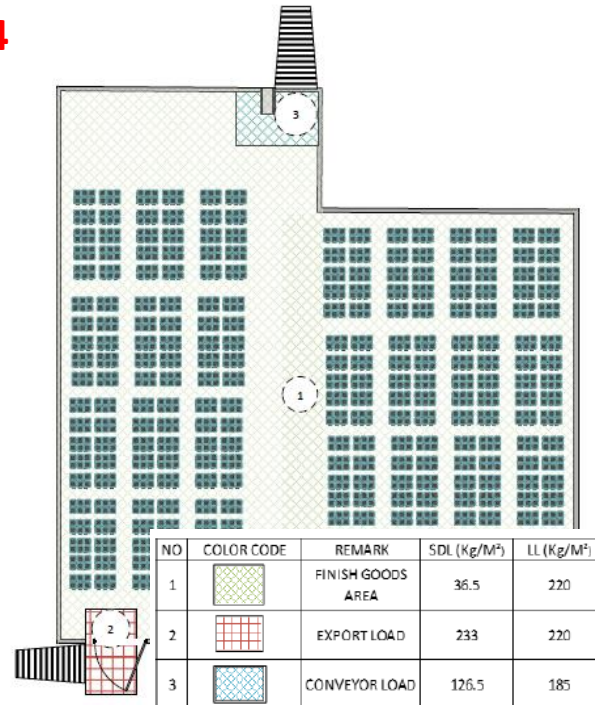

# Questions?

For further queries, contact:



**Julius Yahya, Factory Coordinator – [yahya@labsinitiative.com](mailto:yahya@labsinitiative.com)**

**Nasrulloh, Factory Coordinator – [nasrulloh@labsinitiative.com](mailto:nasrulloh@labsinitiative.com)**

**Wirabawa, Country Manager – [wirabawa@labsinitiative.com](mailto:wirabawa@labsinitiative.com)**

Thank you!

